

GACO SARL

28, Rue Bencharif Madani

25000 BELLEVUE / CONSTANTINE - ALGERIE

Tel. : 031 92 54 56 / 031 93 22 23 - Fax : 031 92 13 45

Email : gacosarl@gmail.com / benkobbi_fares@yahoo.fr

Item : **Item 16**Typ : **Cubic****FRIGA-BOHN****3C-A 4364 L (Multi Refrigerant)****Total capacity : 18,57 kW****DT1 (Dew) / DTM (Mean) : 8 / 8,2 K****Operating conditions**

Refrigerant :	R404A
Room temperature :	0 °C
Unit number :	1

Thermal capacity (per unit)

Capacity per unit :	18,57 kW
DT1 (Dew) / DTM (Mean) :	8 / 8,2 K

Coil characteristics (per unit)

Surface :	38.2 m ²
Volume :	8,7 dm ³
Fin spacing :	6 mm

Dimensional characteristics (per unit)

Empty net weight :	81 kg
Packaging (L/D/H) :	2320 / 750 / 750 mm
Packed unit weight :	129 kg
Standard packaging :	Pallet

Aeraulic characteristics (per unit)

Nb. and diameter of fans :	3 x 450 mm
Air flow-rate :	17540 m ³ /h
Pressure :	0 Pa
Air throw :	36 m
Lp (at 4m) :	53 dB(A)

Electrical characteristics (per unit)

Rotation speed :	1370 tr/min
Maximum input power :	3 x 500 W
Maximum operating current :	3 x 1, A
Motor coupling :	Delta
Voltage/ Nb Phases / Frequency :	400V / 3 / 50Hz

(1) The average acoustic pressure level in dB(A) measured at 4 m, at fan height, in direct line of sight on a reflective surface, are given as an example. Only the acoustic pressure spectrum and Lw value, are contractually binding and may be used to evaluate the pressure characteristics at the property boundaries.

GACO SARL

28, Rue Bencharif Madani

25000 BELLEVUE / CONSTANTINE - ALGERIE

Tel. : 031 92 54 56 / 031 93 22 23 - Fax : 031 92 13 45

Email : gacosarl@gmail.com / benkobbi_fares@yahoo.frItem : **Item 16**Typ : **Cubic**

Options 3C-A 4364 L

- E1U : Light electric defrost: 3 coil heaters
- E1K : Light electric defrost: 3 coil heaters
- E2K : Intermediate electric defrost: 2 coil heaters + 1 drain pan heater + intermediate drain pan.
- E3K : Full electric defrost: 5 coil heaters + 1 drain pan heater + intermediate drain pan.
- BXT : Blygold Polual XT coil protection.
- BAE : Paint coil protection.
- M60 : Fan 230-400V/3/60hz (Ø 450mm) or 230V/1/60Hz (Ø 300mm).
- MM5 : Fan 230V/1/50Hz (Ø 450mm).
- THD : Defrost thermostat (5709L).
- THS : Safety thermostat (5708L).
- 2TH : Defrost and safety thermostats (5709L + 5708L).
- HG1 : Hot gas (coil: hot gas, drain pan : electrical heaters)
- EIS : Insulated drain pan.
- RVU : Shell defrost heaters.
- RVK : Shell defrost heaters.
- DPK : Intermediate drain pan Kit (3C-A .. R/L).
- DMP : Expansion valve fitted Plus (With liquid line)
- EEC : EVL + copper siphon equipped with a ball valve
- PEI : White painted casing.
- EVL : DMP + solenoid valve fitted.
- BHE : Heresite coil protection.
- CIN : 316L Stainless steel frame.
- DEG : Hot glycol water defrost.
- PGI : Stainless steel end place
- EXT : Extronic (Multirefrigerant electronic expansion valve mounted)
- STK : Safetronic Kit (Close expansion valve in case of power failure)
- MP5 : Pressure fan 50 Pa
- VGT : Flange for textile duct

GACO SARL

28, Rue Bencharif Madani

25000 BELLEVUE / CONSTANTINE - ALGERIE

Tel. : 031 92 54 56 / 031 93 22 23 - Fax : 031 92 13 45

Email : gacosarl@gmail.com / benkobbi_fares@yahoo.fr



Item : **Item 16**

Typ : **Cubic**

Model : 3C-A 4364 L

(Drawings are only indicative)

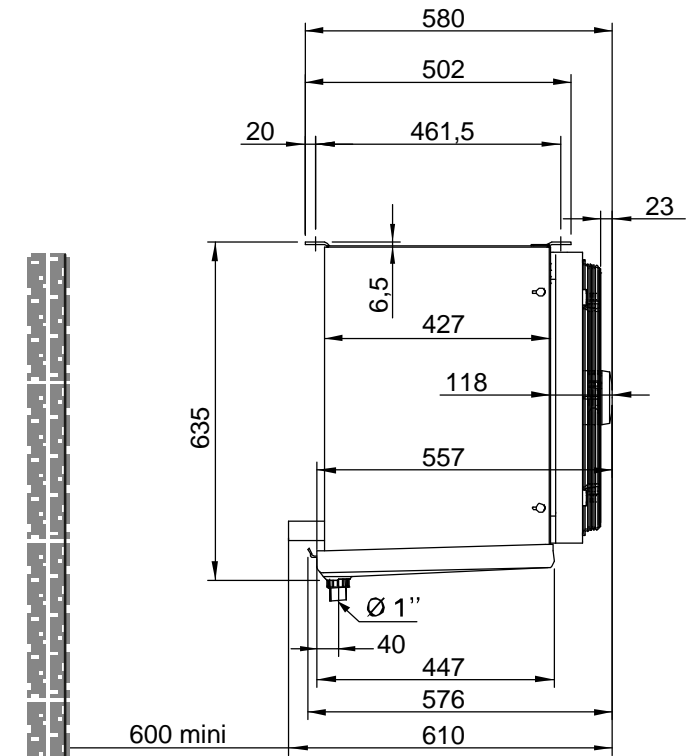
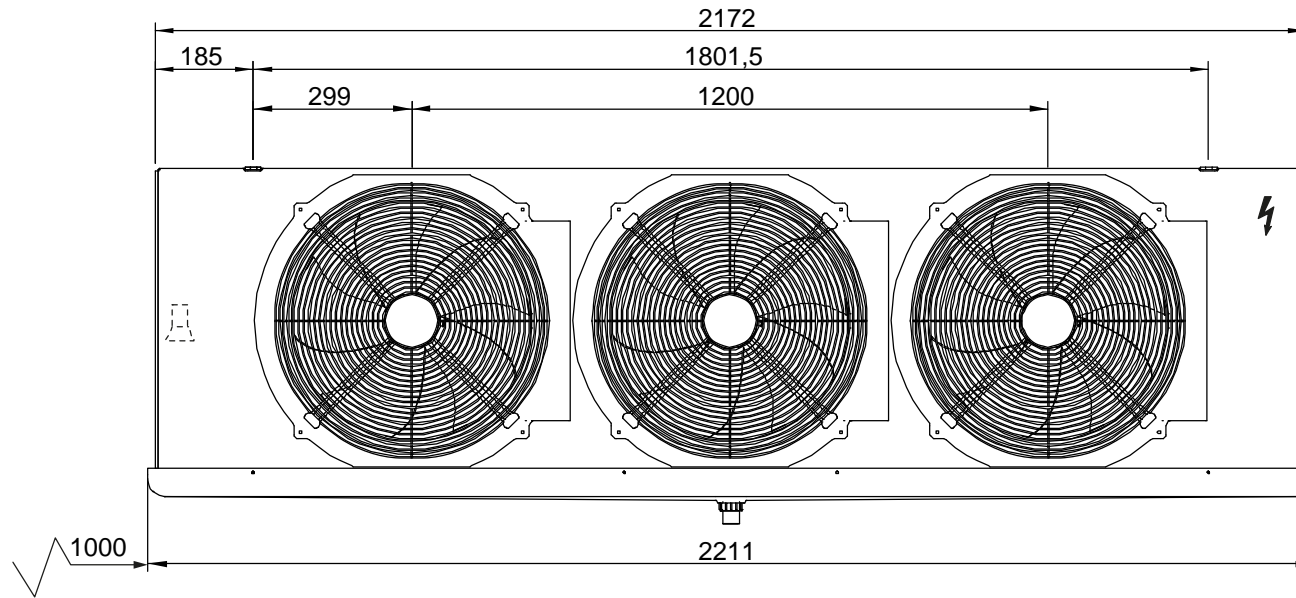

In = 1" 1/8 - Out = 1" 5/8